

# VCD 203/250 (WH)

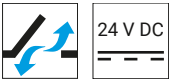
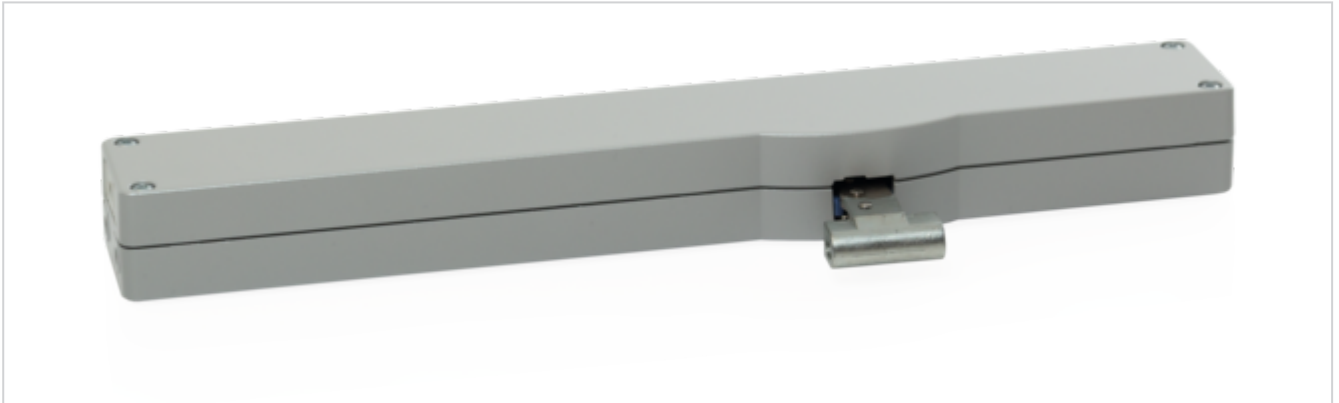

## Performance features

- + For façade windows, roof windows and ventilation flaps in conservatories
- + With motor electronics controlled via microprocessor
- + "TMS+" tandem safety function for operating 2 drives on one sash
- + Option of chain stroke programming via magnet
- + Reprogrammed opening stroke is transmitted to the tandem drive
- + Simple connection via plug connector
- + Programmable drive functions and different drive parameters
- + Running speed in CLOSED direction decreases to 5 mm/s (passive closing edge protection)
- + Time-controlled reversing when an obstacle is detected in the CLOSED direction (active closing edge protection)
- + With optional burglary-resistant effect and maximum locking force of 4000 N

# Approvals / Certificates

Find out about permission details from your D+H Partner.



Article also available with the following permissions under other article numbers. Technical data may deviate.



## Technical data

### VCD 203/250 (WH)

<b>Supply</b>	24 V DC / $\pm 20\%$ / 0.35 A
<b>Duty cycle</b>	30 % (ON: 3 min. / OFF: 7 min.)
<b>Force of pressure</b>	200 N
<b>Tensile force</b>	200 N
<b>Nominal locking force **</b>	2000 N / 4000 N ***
<b>Service life</b>	20000 double strokes *
<b>Stroke</b>	250 mm
<b>OPEN running speed</b>	6 mm/s
<b>CLOSED running speed</b>	6 mm/s
<b>Type of protection</b>	IP 30
<b>Emission sound pressure level</b>	LpA $\leq$ 46 dB(A)
<b>Temperature range</b>	0 °C ... +60 °C
<b>Housing</b>	Die-cast zinc
<b>Surface</b>	Powder-coated
<b>Colour</b>	White (~ RAL 9016)
<b>Connection</b>	2.5 m PVC-cable
<b>W x H x D</b>	300 x 30 x 47 mm
<b>Weight</b>	1.4 kg
<b>Art. No.</b>	25.150.06

\* For vertical use, please consult with D+H Sales!

\*\* Depending on the mounting, \*\*\* optionally increased nominal locking force

# Dimensions

All specifications in mm

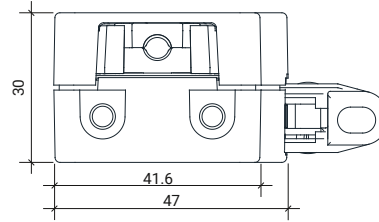
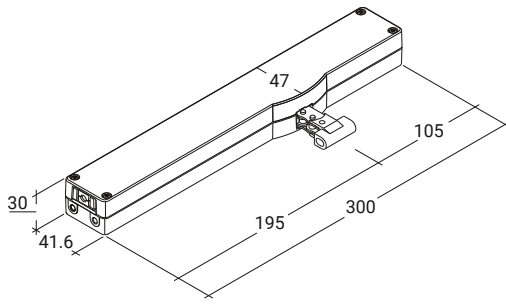

# Pressure load diagram

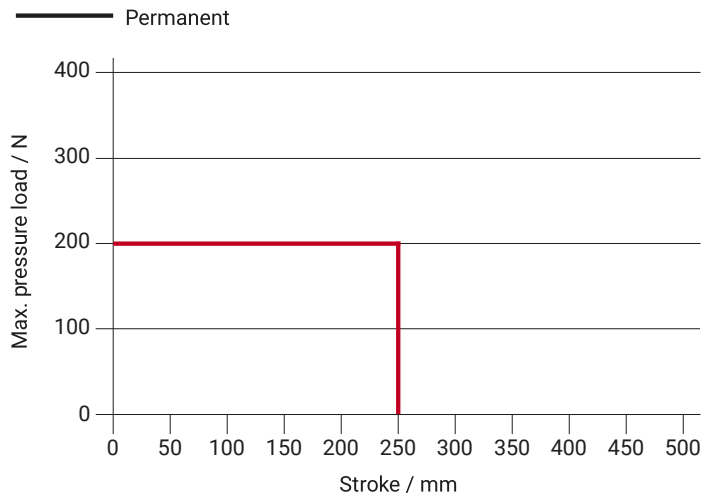

# Possible applications

- + Mounted installation
- + Frame mounting
- + Sash mounting
- + Application force
- + Application tension

